

## Technical report

Art.

### HP 20 R



Art.	HP 20 R
Product	ADJUSTABLE HINGE WITH PLATE, FIXED
Item code	1700380
Material	Body - S 355 J2C, „C“ claim - S 235 JR, Plate - S235 JR, Pin - 11SMn30, Hexagon - 11SMn30, Rivet nut - 11SMn30, Retaining ring - DIN 6799
Surface finish	ČSN EN ISO 19598 - Fe//Zn12//Cn//T2nL

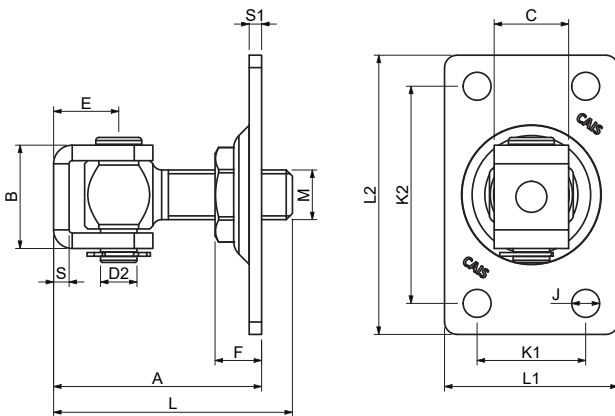

Art.	M	L1	L2	A min./max.	L	B	C	D2	E	F	J	K1	K2	S	S1	1pc		CODE	
				mm					mm			mm			kg	pcs	kg		
HP 20 R	M20	74	100	60 - 88	88	39	28	14	25	19	11	45	71	6	4	0,62	10	6,2	1700380

\*All specifications, photographs and technical drawings are the property of CAIS s. r. o. and are protected by copyright. Product specifications can be changed without prior notice.

## 1) HINGE SPACING

$$HS = \min. 75\% H$$

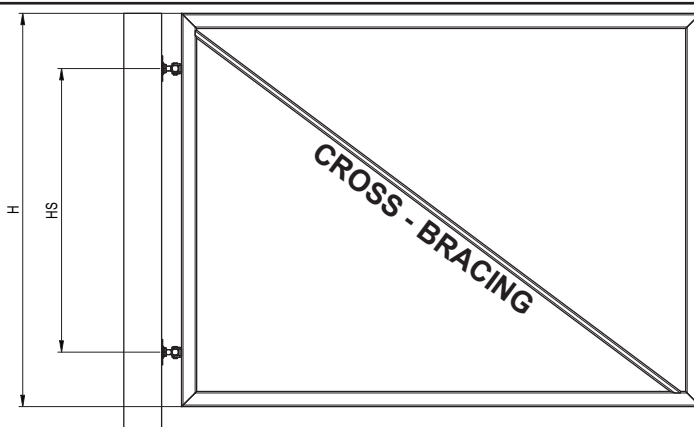

## 2) ASPECT RATIO

$$L/H \leq 2$$

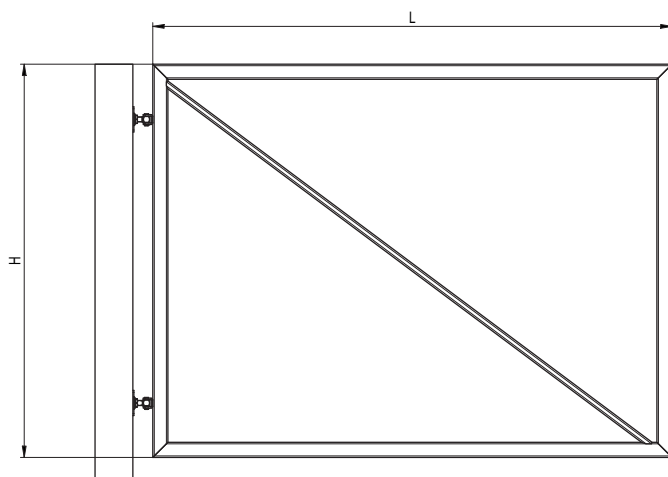

## 3) ASPECT RATIO

$$L = \max. (H + 40\% H)$$

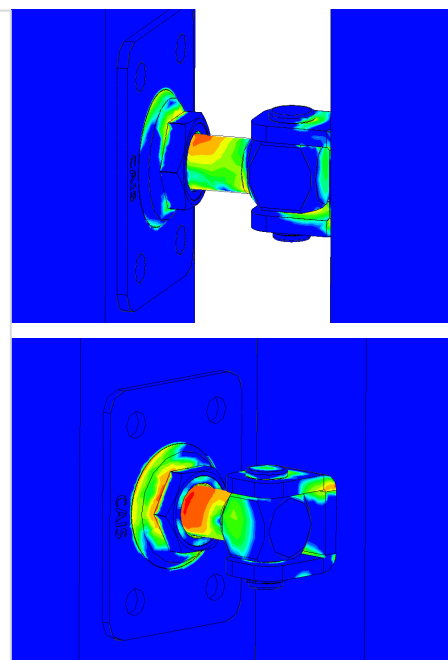
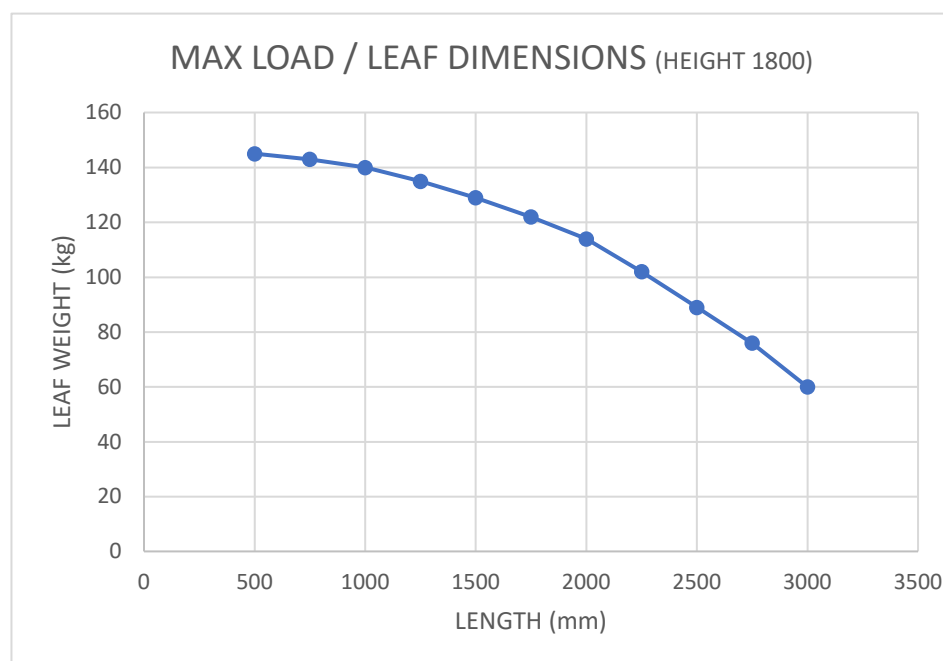

Art.	"MAX WIDTH"	"MAX HEIGHT"	"MAX"	"MAX CAPACITY"	CYCLES	MAINTENANCE
	mm		m2	1 pair/kg	nr	
HP 20 R	3000	2500	5,5	145	200 000	Greasing „every 25 000 cycles / 1 times per year“

\*All specifications, photographs and technical drawings are the property of CAIS s. r. o. and are protected by copyright. Product specifications can be changed without prior notice.